

RDH E_-0400

Performance certified is for installation type B - free inlet, ducted outlet.
 Power rating (kW) does not include transmission losses.
 Performance ratings do not include the effects of appurtenances (accessories).

Technical Data

Impeller Data

Impeller diameter	D_r	402 mm
Number of blades	z	11
Moment of Inertia	J	0,330 kgm ²

Impeller Data

Impeller weight	m	12,7 kg
Density of media	ρ_1	1,2 kg/m ³
Tolerance class (DIN 24166)		1

Performance Curves

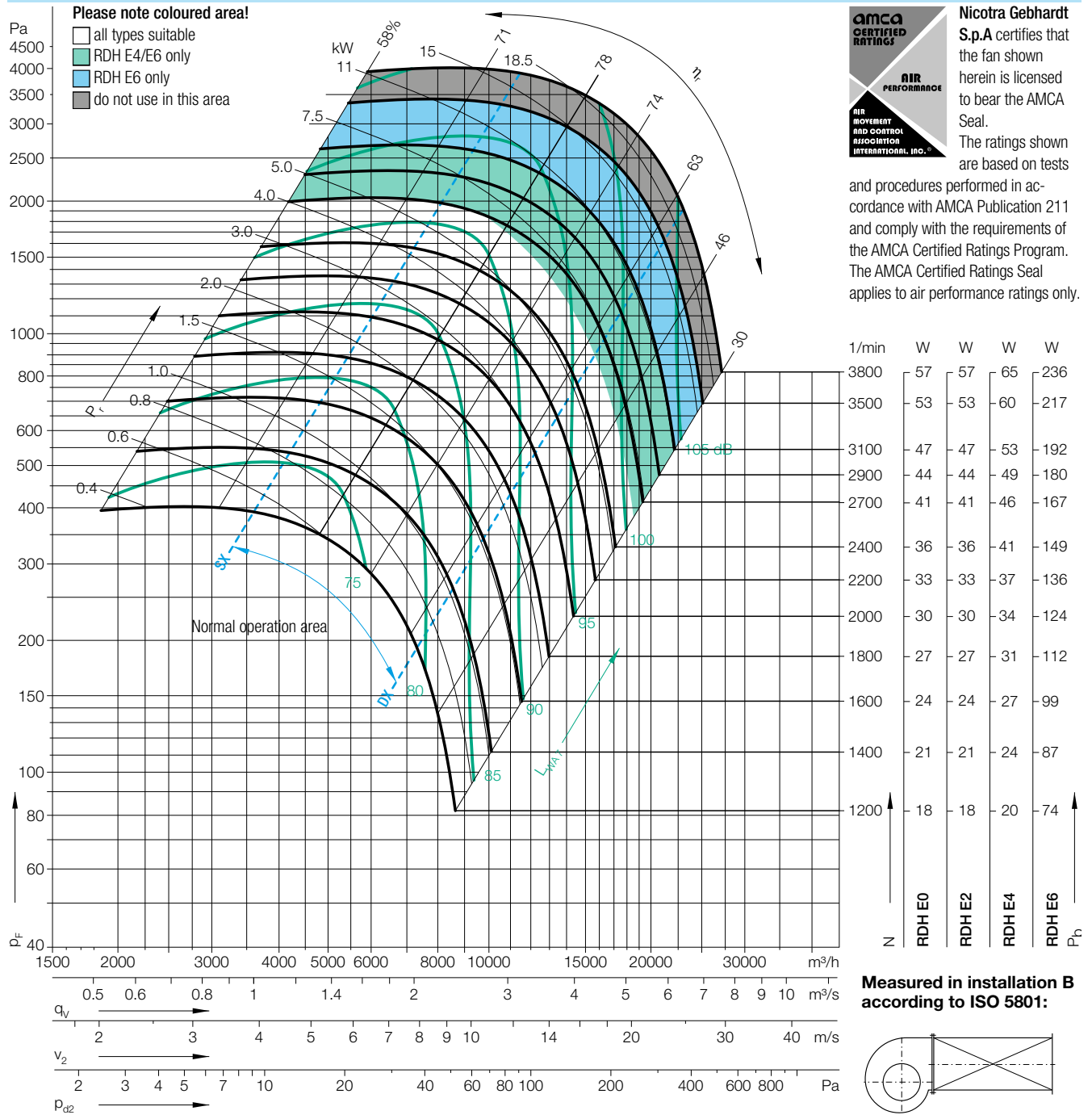

Nicotra Gebhardt S.p.A certifies that the fan shown herein is licensed to bear the AMCA Seal. The ratings shown are based on tests

and procedures performed in accordance with AMCA Publication 211 and comply with the requirements of the AMCA Certified Ratings Program. The AMCA Certified Ratings Seal applies to air performance ratings only.

$\Delta L_{Wrel4}(A)$

Duty point	Speed 1/min	dB
SX	3100	3
SX	2400	3
SX	1400	3
$Q_{V,opt}$	3100	3
$Q_{V,opt}$	2400	3
$Q_{V,opt}$	1400	3
DX	3100	2
DX	2400	3
DX	1400	3

Relative sound power level for inlet side L_{Wrel7} at octave centre frequencies f_c

63	125	250	500	1000	2000	4000	8000	Hz
-7	-3	-4	-1	-6	-10	-11	-16	dB
-5	-3	-3	-1	-6	-8	-13	-17	dB
0	0	3	-3	-6	-9	-13	-17	dB
-9	-7	-7	-1	-6	-9	-10	-17	dB
-8	-7	-7	-1	-6	-8	-13	-18	dB
-4	-4	2	-4	-5	-8	-14	-18	dB
-7	-8	-8	-1	-7	-9	-10	-17	dB
-7	-8	-8	0	-7	-8	-12	-20	dB
-5	-5	2	-4	-5	-8	-15	-21	dB

Relative sound power level for discharge side L_{Wrel4} at octave centre frequencies f_c

63	125	250	500	1000	2000	4000	8000	Hz
10	7	3	-1	-4	-4	-8	-15	dB
10	6	2	-2	-2	-4	-11	-16	dB
10	6	6	0	-1	-7	-12	-16	dB
7	4	-1	0	-4	-3	-8	-15	dB
10	7	3	0	-2	-3	-11	-17	dB
6	2	6	-1	0	-6	-13	-18	dB
6	2	-2	0	-4	-4	-7	-15	dB
5	0	-3	0	-4	-3	-10	-17	dB
5	1	6	-1	-1	-5	-13	-19	dB

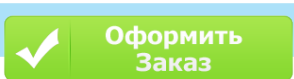

RDH E_-0400

Dimensions in mm, subject to change.

RDH E0-0400 36 kg

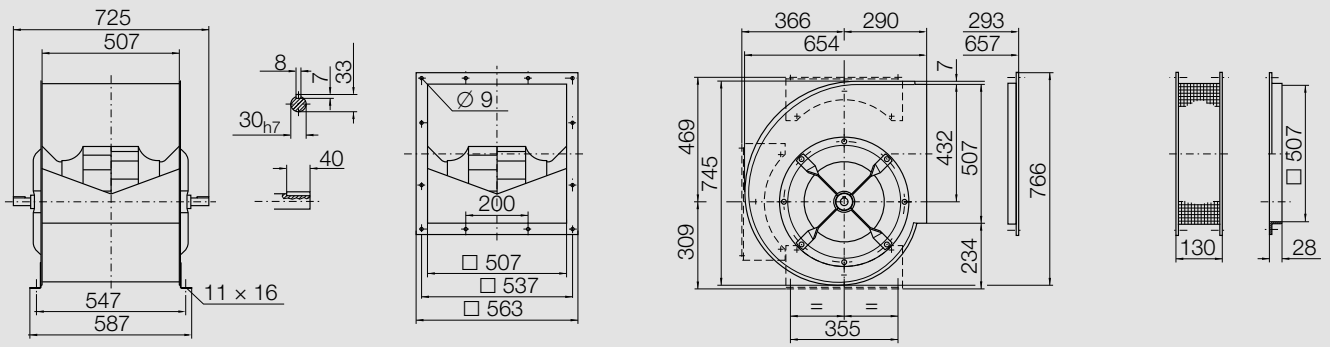

RDH E2-0400 42 kg

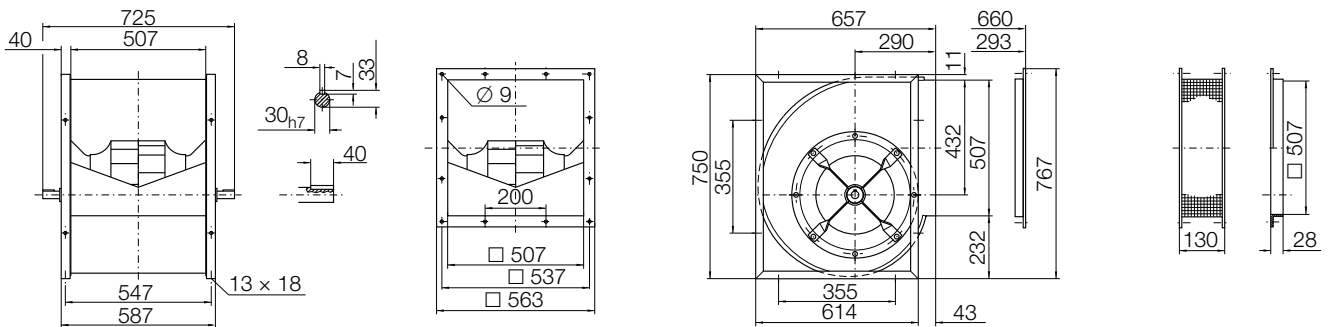

RDH E4-0400 57 kg

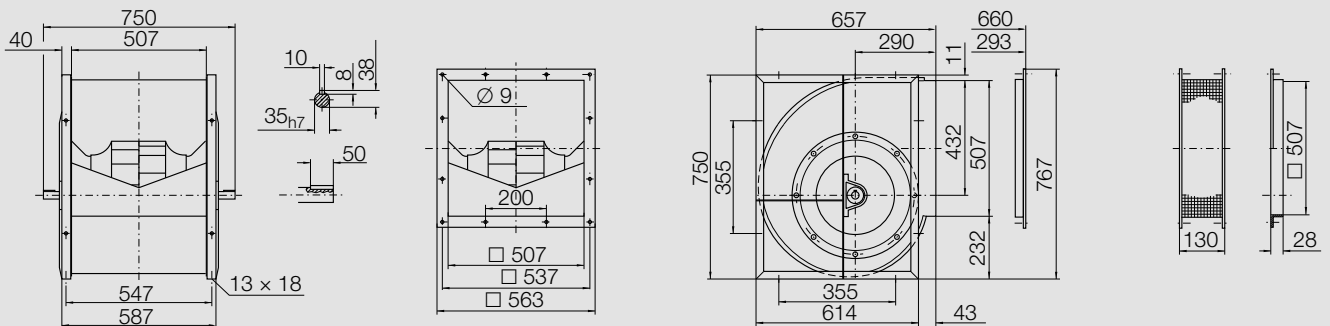

RDH E6-0400 58 kg

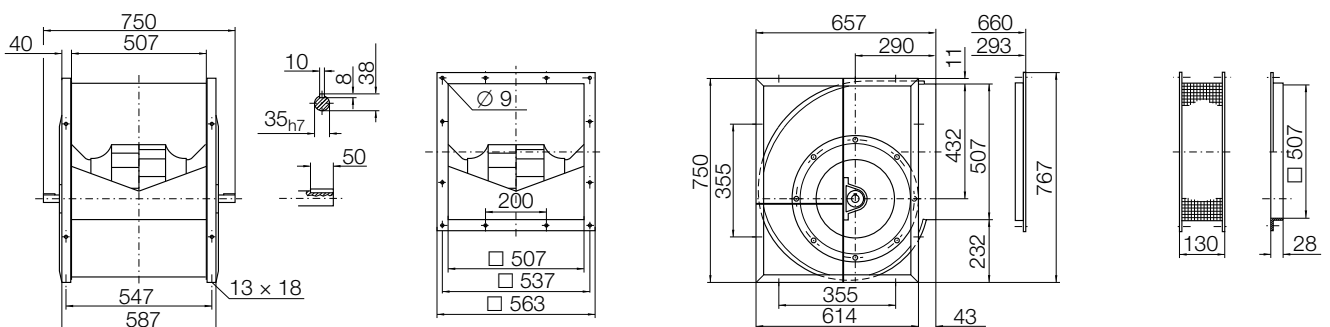

Оформить
Заказ