

Diameter:

710 mm

R14_-71AP_-ES80B-05A02



Nominal data according to standard IEC 60034 (max. load):	
Phase	1~
Nominal voltage	230 V
Nominal voltage range	200-277 V
Frequency	50-60 Hz
Input power	400 W
Input current	1.7 A
Nominal speed	700 RPM
Min. ambient temperature	-25 °C
Protection class	IP54
Insulation class	130

ErP data according to EU regulation 327/2011:	
Overall efficiency	51.0 %
Measurement category	A
Efficiency category	static
Efficiency grade N	59.8
Variable speed drive	INTEGRATED
Power input	0.42 kW
Air flow	9324 m ³ /h
Pressure drop	77 Pa
Rotational speed	717 RPM
Specific ratio	1.00

General notes	
Connection diagram: 0302-0-1005	See section Connection diagrams
Guard grills & wall-plates	See section Accessories
Standards compliance	See introduction page

Dimensions and fan ordering information



Type: R14R-71APS-ES80B-05A02
Code: 0314-4-0059
Weight: 16.4 kg

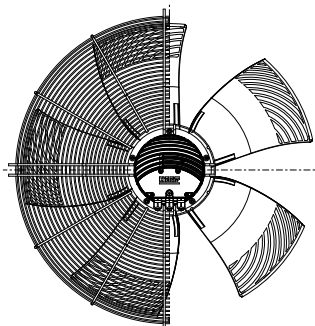
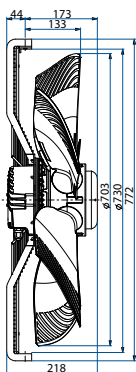

Type: R14P-71APS-ES80B-05A02
Code: 0314-4-0060
Weight: 27.4 kg

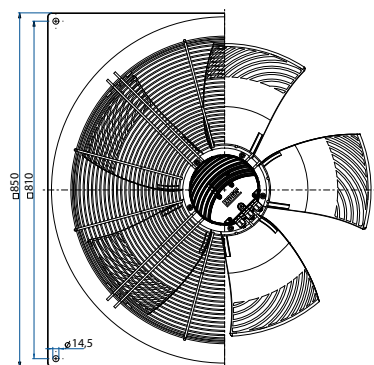
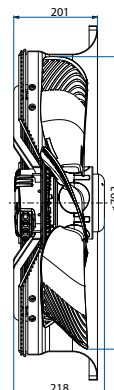

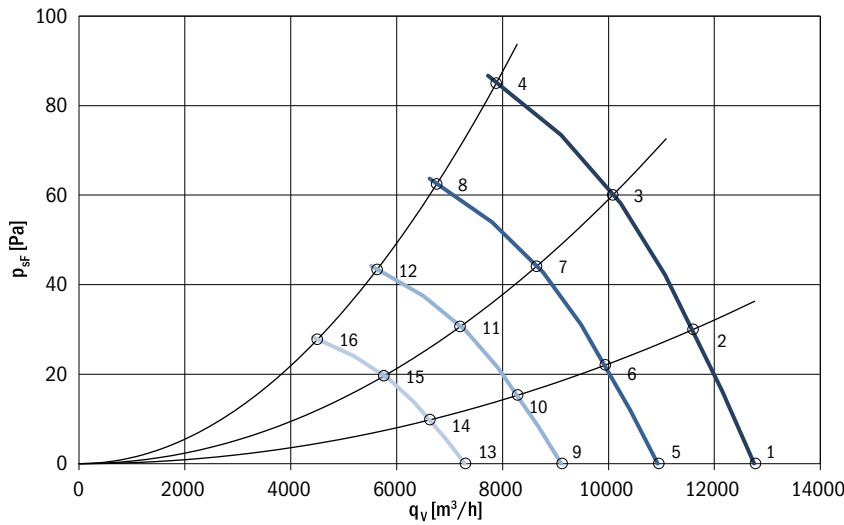

Aerodynamic characteristic:

- measured in full bell mouth without guard grill
- installation category A according to ISO 5801

Sound power level:

- measured on pressure side
- fan mounted in full bell mouth without guard grill
- measured according to ISO 3741; installation type A

The values given may vary according to actual installation in the unit.

Definition of symbols

- U [V]** Supply voltage
- f [Hz]** Frequency
- n [RPM]** Fan speed
- q_v [m³/h]** Air flow
- p_{sf} [Pa]** Pressure drop
- P_e [W]** Power input
- I [A]** Current
- L_{wa} [dB (A)]** Sound power level A weighted
- T_{a max} [°C]** Max. ambient temperature

	U [V]	f [Hz]	n [RPM]	q _v [m ³ /h]	p _{sf} [Pa]	P _e [W]	I [A]	L _{wa out} [dB (A)]	T _{a max} [°C]
1	230	50	700	12780	0	300	1.30	70	60
2	230	50	700	11600	30	364	1.57	66	60
3	230	50	700	10080	60	405	1.73	65	60
4	230	50	700	7880	85	435	1.87	68	60
5	230	50	600	10954	0	189	0.82	68	60
6	230	50	600	9943	22	229	0.99	63	60
7	230	50	600	8640	44	255	1.09	62	60
8	230	50	600	6754	62	274	1.18	65	60
9	230	50	500	9129	0	109	0.47	63	60
10	230	50	500	8286	15	133	0.57	59	60
11	230	50	500	7200	31	148	0.63	58	60
12	230	50	500	5629	43	159	0.68	61	60
13	230	50	400	7303	0	56	0.24	57	60
14	230	50	400	6629	10	68	0.29	53	60
15	230	50	400	5760	20	76	0.32	52	60
16	230	50	400	4503	28	81	0.35	55	60



Type: R14R-71APB-ES80B-05A02
Code: On request
Weight:



Type: R14P-71APB-ES80B-05A02
Code: On request
Weight: