

Diameter:

300 mm

R09_-3018H_-2M-4248



Fan with guard grill

Airflow Direction	Type	Code	Weight (kg)
Sucking	R09R-3018HA-2M-4248	0309-4-1093	3.5
Blowing	R09R-3018HP-2M-4248	0309-4-1094	

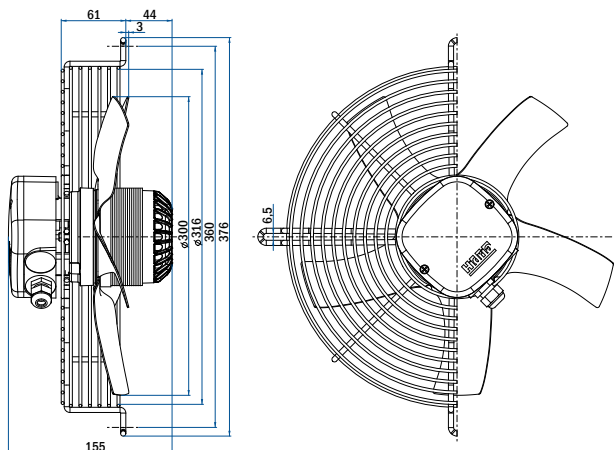

Fan with plate

Airflow Direction	Type	Code	Weight (kg)
Sucking	R09P-3018HA-2M-4248	On request	
Blowing	R09P-3018HP-2M-4248	On request	

Fan without guard grill

Airflow Direction	Type	Code	Weight (kg)
Sucking	R09E-3018HA-2M-4248	On request	
Blowing	R09E-3018HP-2M-4248	On request	

Nominal data according to standard EN 60335:	
Phase	1~
Nominal voltage	230 V
Frequency	50/60 Hz
Rated power input	140/190 W
Rated current	0.62/0.83 A
Rated speed	2590/2700 RPM
Min. ambient temperature	-30 °C
Max. ambient temperature	55/40 °C
Sound power level A weighted	83/87 dB (A)
Condensator	5 µF/450 V
Connection	terminal box
Insulation class	155
Protection class	IP54

ErP data according to EU regulation 327/2011:	
Overall efficiency	29.0 %
Measurement category	A
Efficiency category	static
Efficiency grade N	40.2
Variable speed drive	NO
Power input	169 W
Air flow	1553 m³/h
Pressure drop	118 Pa
Speed	2585 RPM
Specific ratio	1.00

Aerodynamic characteristic

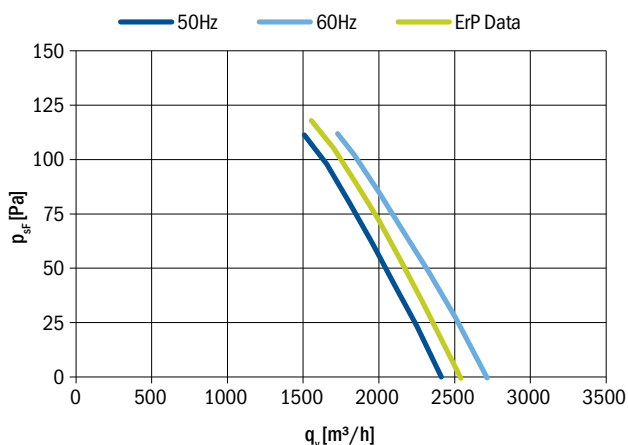

Fan characteristic measured in full bell mouth with guard grill.
ErP characteristic measured in full bell mouth without guard grill.

General notes	
Connection diagrams:	
Sucking	0301-1-0043 See section
Blowing	0301-1-0044 Connection diagrams
Guard grills & wall-plates	See section Accessories
Standards compliance	See introduction page