

S6E450-AP02-01

AC axial fan - HyBlade®

sickled blades (S series)
with guard grille for short nozzle

ebm-papst Mulfingen GmbH & Co. KG

Bachmühle 2 · D-74673 Mulfingen

Phone +49 7938 81-0

Fax +49 7938 81-110

info1@de.ebmpapst.com

www.ebmpapst.com

Limited partnership · Headquarters Mulfingen

County court Stuttgart · HRA 590344

General partner Elektrobau Mulfingen GmbH · Headquarters Mulfingen

County court Stuttgart · HRB 590142



Nominal data

Type	S6E450-AP02-01		
Motor	M6E074-GA		
Phase		1~	1~
Nominal voltage	VAC	230	230
Frequency	Hz	50	60
Type of data definition		fa	fa
Valid for approval / standard		CE	CE
Speed	min ⁻¹	940	1070
Power input	W	165	225
Current draw	A	0.8	0.98
Motor capacitor	µF	4	4
Capacitor voltage	VDB	450	450
Max. back pressure	Pa	70	45
Min. ambient temperature	°C	-25	-25
Max. ambient temperature	°C	60	60
Starting current	A	1.5	1.4

ml = Max. load · me = Max. efficiency · fa = Running at free air · cs = Customer specs · cu = Customer unit
Subject to alterations

Data according to ErP directive

Installation category	A
Efficiency category	Static
Variable speed drive	No
Specific ratio*	1.00

* Specific ratio = $1 + p_g / 100\,000\text{ Pa}$

		Actual	Request 2013	Request 2015
Overall efficiency η_{es}	%	25	25	29
Efficiency grade N		36	36	40
Power input P_e	kW	0.18		
Air flow q_v	m ³ /h	3105		
Pressure increase p_{fs}	Pa	51		
Speed n	min ⁻¹	895		

Data definition with optimum efficiency. LU-78077
The ErP data is determined using a motor-impeller combination in a standardised measurement configuration.



S6E450-AP02-01

AC axial fan - HyBlade®

sickled blades (S series)

with guard grille for short nozzle

Technical features

Mass	7.19 kg
Size	450 mm
Surface of rotor	Coated in black
Material of impeller	Sheet steel, coated in black
Material of guard grille	Steel, phosphated and coated in black plastic
Number of blades	5
Direction of air flow	"V"
Direction of rotation	Counter-clockwise, seen on rotor
Type of protection	IP 44; Depending on installation and position
Insulation class	"F"
Humidity class	F1-2
Max. permissible ambient motor temp. (transp./ storage)	+80 °C
Min. permissible ambient motor temp. (transp./storage)	-40 °C
Mounting position	Shaft horizontal or rotor on bottom; rotor on top on request
Condensate discharge holes	Rotor-side
Operation mode	S1
Motor bearing	Ball bearing
Touch current acc. IEC 60990 (measuring network Fig. 4, TN system)	< 0.75 mA
Motor protection	Thermal overload protector (TOP) wired internally
Cable exit	Variable
Protection class	I (if protective earth is connected by customer)
Product conforming to standard	EN 60335-1; CE
Approval	CCC; EAC

S6E450-AP02-01

AC axial fan - HyBlade®

sickled blades (S series)
with guard grille for short nozzle

Product drawing

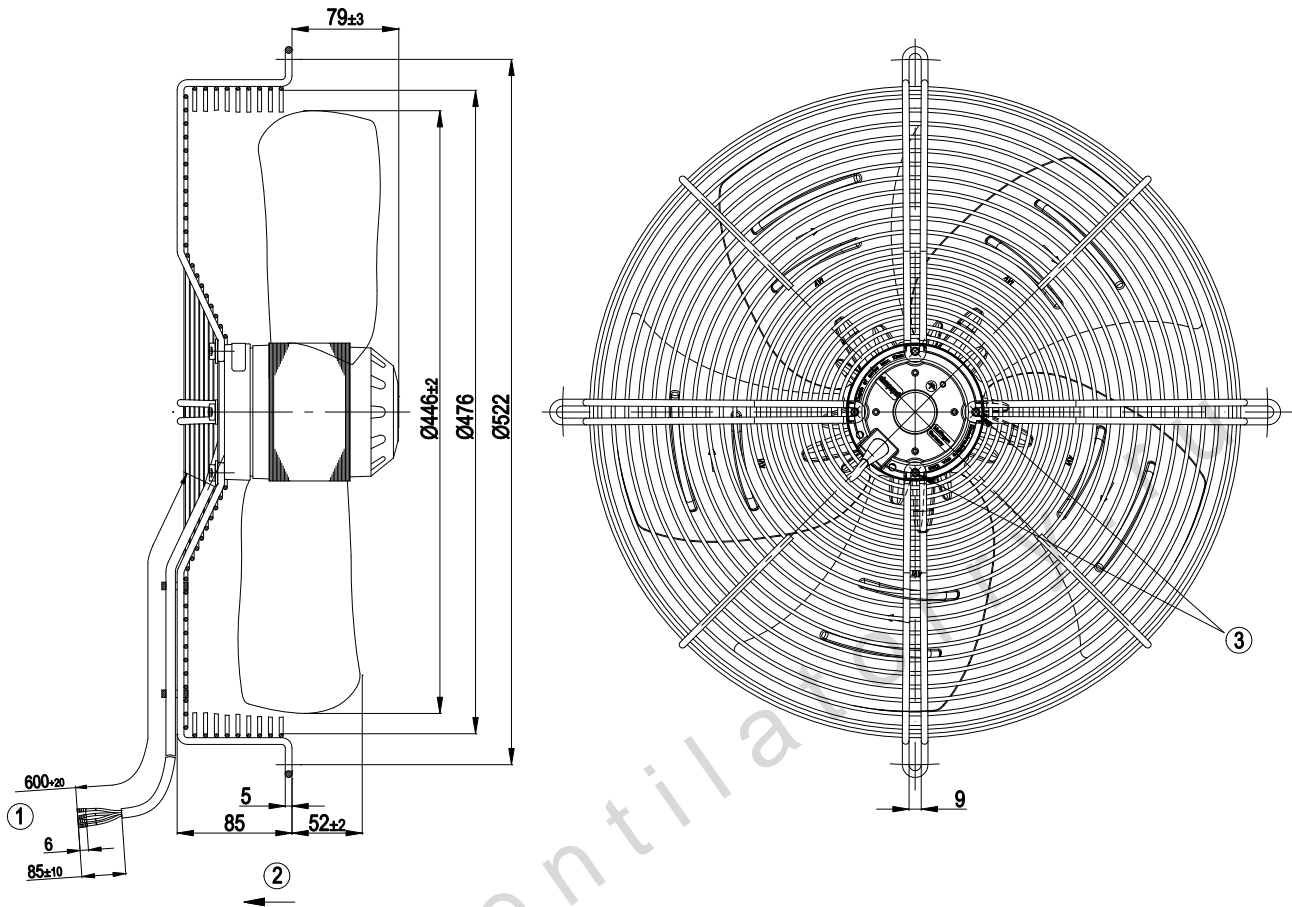

1	Connection line AWG20; 4 x brass lead tips crimped
2	Direction of air flow "V"
3	Cable diameter: min. 6 mm, max. 12 mm; tightening torque: 0.8 ± 0.15 Nm

Connection screen

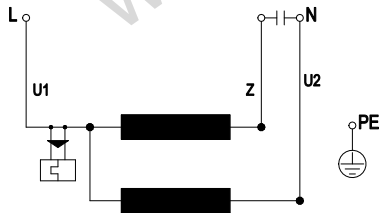

U1	blue	Z	brown	U2	black
PE	green/yellow				

S6E450-AP02-01

AC axial fan - HyBlade®

sickled blades (S series)

with guard grille for short nozzle

Charts: Air flow 50 Hz

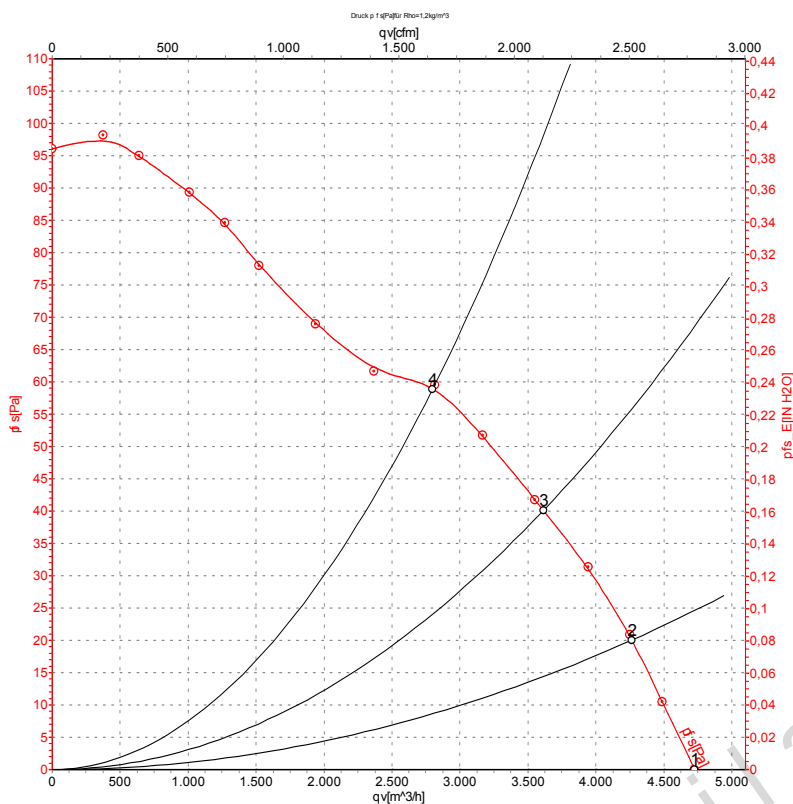

Air performance measured as per ISO 5801 Installation category A. For detailed information on the measuring set-up, please contact ebm-papst. Suction-side noise levels: LwA measured as per ISO 13347 / LpA measured with 1m distance to fan axis. The values given are valid under the measuring conditions mentioned above and may vary according to the actual installation situation. With any deviation from the standard set-up, the specific values have to be checked and reviewed with the unit installed.

Measured values

	U	f	n	P _e	I	qv	P _{fs}
	V	Hz	min ⁻¹	W	A	m ³ /h	Pa
1	230	50	940	165	0.80	4725	0
2	230	50	925	173	0.82	4265	20
3	230	50	910	180	0.85	3615	40
4	230	50	895	190	0.89	2800	60

U = Supply voltage · f = Frequency · n = Speed · P_e = Power input · I = Current draw · qv = Air flow · P_{fs} = Pressure increase



S6E450-AP02-01

AC axial fan - HyBlade®

sickled blades (S series)

with guard grille for short nozzle

Charts: Air flow 60 Hz

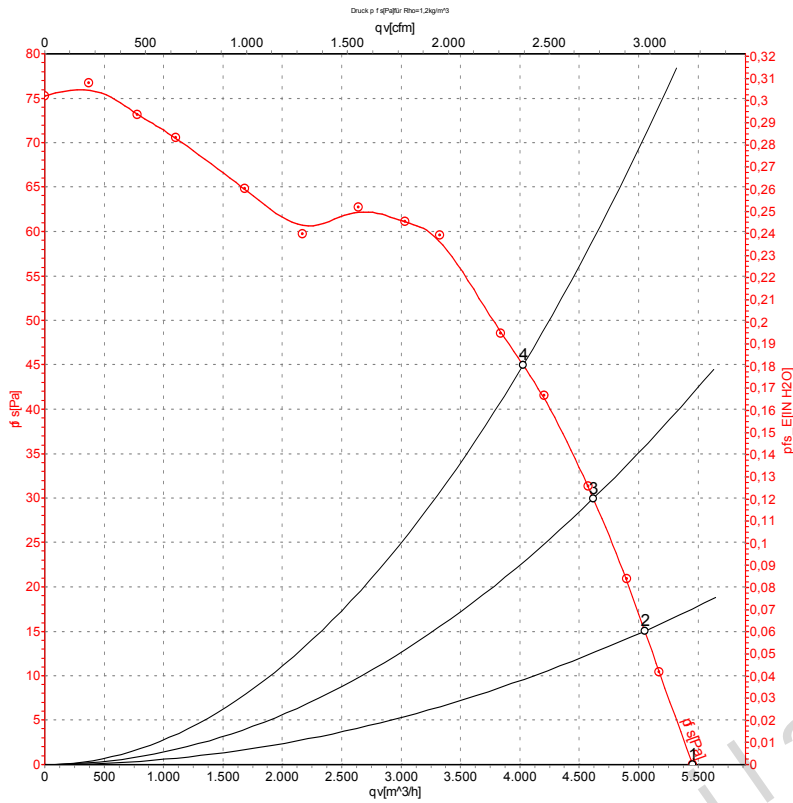

Air performance measured as per ISO 5801 Installation category A. For detailed information on the measuring set-up, please contact ebm-papst. Suction-side noise levels: LwA measured as per ISO 13347 / LpA measured with 1m distance to fan axis. The values given are valid under the measuring conditions mentioned above and may vary according to the actual installation situation. With any deviation from the standard set-up, the specific values have to be checked and reviewed with the unit installed.

Measured values

	U	f	n	P _e	I	qv	P _{fs}
	V	Hz	min ⁻¹	W	A	m ³ /h	Pa
1	230	60	1070	225	0.98	5455	0
2	230	60	1055	225	1.00	5050	15
3	230	60	1030	231	1.03	4620	30
4	230	60	995	238	1.06	4030	45

U = Supply voltage · f = Frequency · n = Speed · P_e = Power input · I = Current draw · qv = Air flow · P_{fs} = Pressure increase

