

S3G800-BO81-21

EC axial fan - HyBlade®

sickled blades (S series)

with guard grille for full nozzle

ebm-papst Mulfingen GmbH & Co. KG

Bachmühle 2 · D-74673 Mulfingen

Phone +49 7938 81-0

Fax +49 7938 81-110

info1@de.ebmpapst.com

www.ebmpapst.com

Limited partnership · Headquarters Mulfingen

County court Stuttgart · HRA 590344

General partner Elektrobau Mulfingen GmbH · Headquarters Mulfingen

County court Stuttgart · HRB 590142



Nominal data

Type	S3G800-BO81-21	
Motor	M3G112-IA	
Phase		1~
Nominal voltage	VAC	230
Nominal voltage range	VAC	200 .. 277
Frequency	Hz	50/60
Type of data definition		ml
State		prelim.
Speed	min ⁻¹	710
Power input	W	730
Current draw	A	3.2
Max. back pressure	Pa	100
Min. ambient temperature	°C	-25
Max. ambient temperature	°C	60

ml = Max. load · me = Max. efficiency · fa = Running at free air · cs = Customer specs · cu = Customer unit
Subject to alterations

Data according to ErP directive

Installation category	A
Efficiency category	Static
Variable speed drive	Yes
Specific ratio*	1.00

* Specific ratio = $1 + p_b / 100\,000\text{ Pa}$

		Actual	Request 2013	Request 2015
Overall efficiency η_{es}	%	43.7	28.6	32.6
Efficiency grade N		51.1	36	40
Power input P_{ed}	kW	0.68		
Air flow q_v	m ³ /h	11680		
Pressure increase p_{fs}	Pa	84		
Speed n	min ⁻¹	715		

Data definition with optimum efficiency.
The ErP data is determined using a motor-impeller combination in a standardised measurement configuration.



S3G800-BO81-21

EC axial fan - HyBlade®

sickled blades (S series)

with guard grille for full nozzle

Technical features

Mass	17.9 kg
Size	800 mm
Surface of rotor	Coated in black
Material of electronics housing	Die-cast aluminium, coated in black
Material of blades	Press-fitted sheet steel blank, sprayed with PP plastic
Material of guard grille	Steel, coated in black plastic (RAL9005)
Number of blades	5
Blade angle	0°
Direction of air flow	"V"
Direction of rotation	Clockwise, seen on rotor
Type of protection	IP 54
Insulation class	"B"
Humidity class	F4-1
Max. permissible ambient motor temp. (transp./ storage)	+80 °C
Min. permissible ambient motor temp. (transp./storage)	-40 °C
Mounting position	Shaft horizontal or rotor on bottom; rotor on top on request
Condensate discharge holes	Rotor-side
Operation mode	S1
Motor bearing	Ball bearing
Technical features	<ul style="list-style-type: none"> - Output 10 VDC, max. 10 mA - Alarm relay - Motor current limit - PFC, active - Soft start - Control input 0-10 VDC Control interface with SELV potential safely disconnected from the mains - Over-temperature protected electronics / motor - Line undervoltage / phase failure detection
EMC interference immunity	Acc. to EN 61000-6-2 (industrial environment)
EMC harmonics	Acc. to EN 61000-3-2/3
EMC interference emission	Acc. to EN 55022 (Class B, household environment)
Motor protection	Thermal overload protector (TOP) wired internally
Cable exit	Variable
Protection class	I (if protective earth is connected by customer)
Product conforming to standard	EN 61800-5-1; CE
Approval	GOST; CCC

S3G800-BO81-21

EC axial fan - HyBlade®

sickled blades (S series)

with guard grille for full nozzle

Product drawing

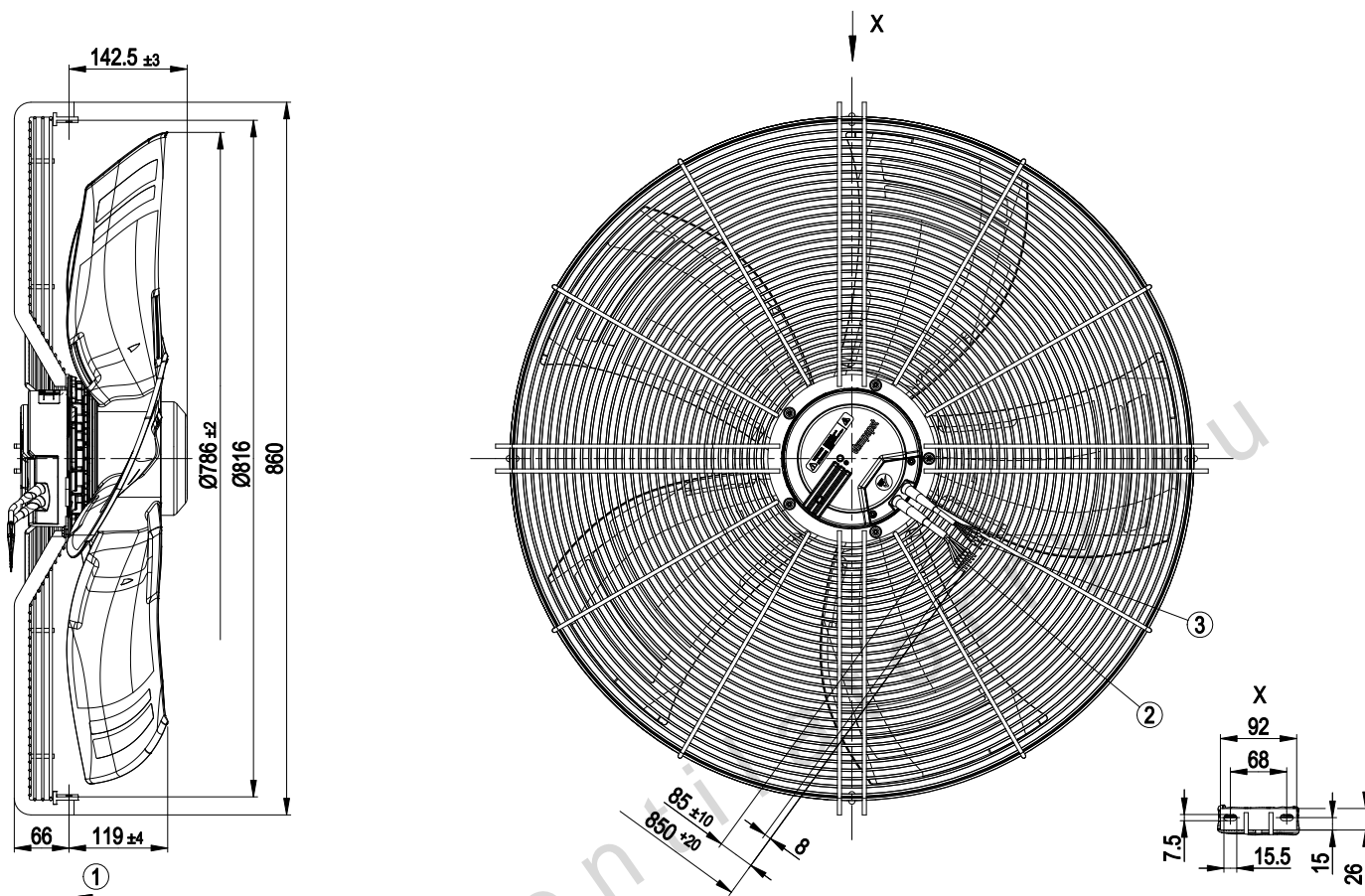

1	Direction of air flow "V"
2	Connection line PVC AWG18, 5x crimped core-end sleeves
3	Connection line PVC AWG22, 3x crimped core-end sleeves

S3G800-BO81-21

EC axial fan - HyBlade®

sickled blades (S series)

with guard grille for full nozzle

Connection screen

Customer circuit

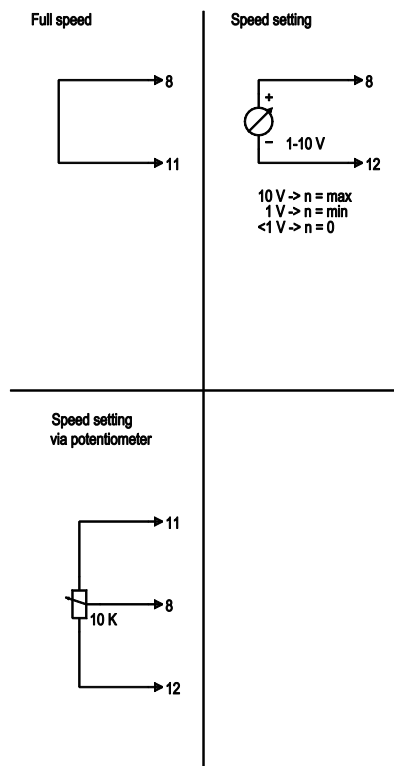

Connection

Fan / motor

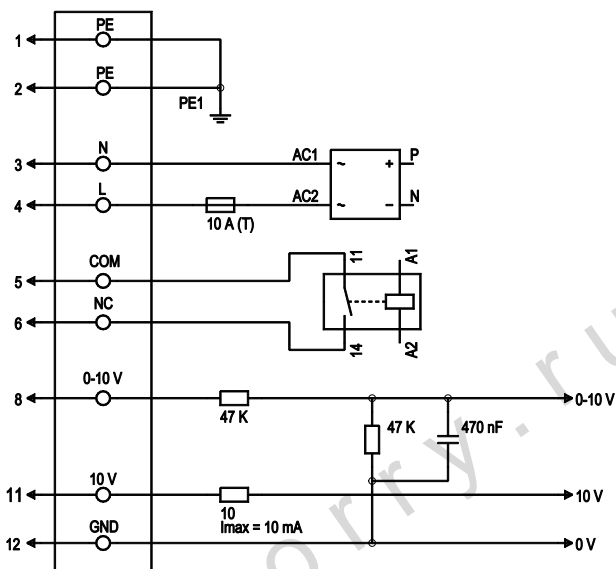

No.	Conn.	Designation	Colour	Function / assignment
1	1,2	PE	green/yellow	Protective earth
1	3	N	blue	Supply voltage, neutral conductor, 50/60 Hz
1	4	L	black	Supply voltage, phase, 50/60 Hz
1	5	COM	white 1	Floating status message contact, break for failure (2 A, max. 250 VAC, min. 10 mA, AC1)
1	6	NC	white 2	Floating status message contact, break for failure
2	8	0-10 V	yellow	Control input, set value 0-10 VDC, impedance 100 kΩ, SELV
2	11	10 VDC	red	Voltage output 10 VDC (+/-3%), max. 10 mA, supply voltage for external devices (e.g. potentiometer), SELV
2	12	GND	blue	Reference mass for control interface, SELV

S3G800-BO81-21

EC axial fan - HyBlade®

sickled blades (S series)

with guard grille for full nozzle

Charts: Air flow 50 Hz

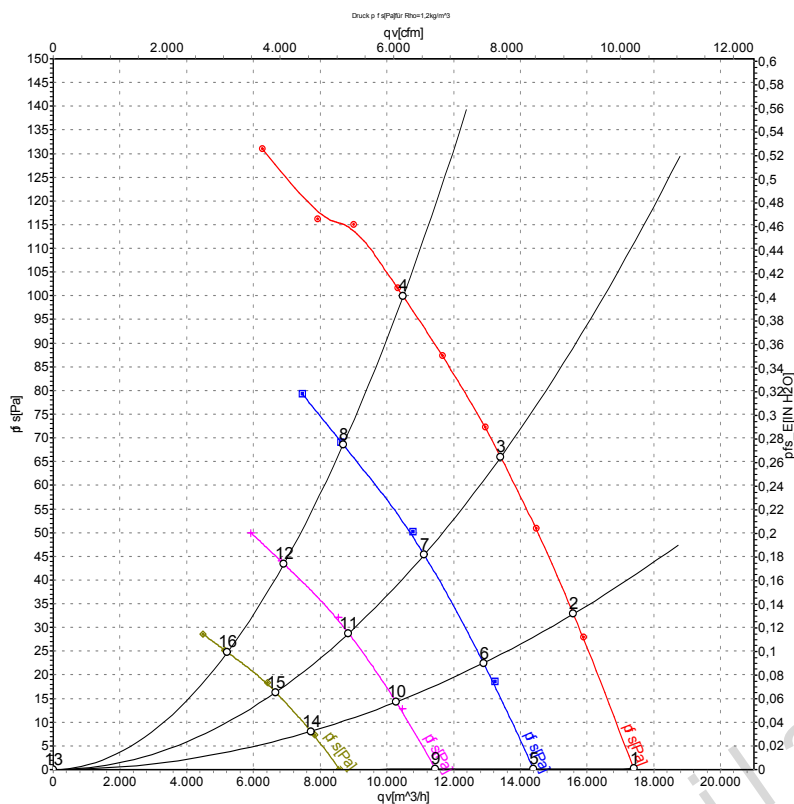

Air performance measured as per ISO 5801 Installation category A. For detailed information on the measuring set-up, please contact ebmpapst. Suction-side noise levels: LwA measured as per ISO 13347 / LpA measured with 1m distance to fan axis. The values given are valid under the measuring conditions mentioned above and may vary according to the actual installation situation. With any deviation from the standard set-up, the specific values have to be checked and reviewed with the unit installed.

Measured values

	U	f	n	P _{ed}	I	LpA _{in}	LwA _{in}	LwA _{out}	qv	p _{fs}
	V	Hz	min ⁻¹	W	A	dB(A)	dB(A)	dB(A)	m ³ /h	Pa
1	230	50	710	462	2.15	63	70	70	17400	0
2	230	50	710	549	2.51	60	66	66	15590	33
3	230	50	710	634	2.86	58	65	64	13410	66
4	230	50	710	730	3.20	61	69	69	10490	100
5	230	50	590	264	1.25	59	65	65	14390	0
6	230	50	590	309	1.44	56	62	62	12890	23
7	230	50	590	352	1.64	54	60	60	11120	46
8	230	50	590	395	1.84	57	64	64	8690	69
9	230	50	470	188	0.69	54	60	60	11450	0
10	230	50	470	164	0.78	51	57	57	10270	15
11	230	50	470	186	0.88	49	55	55	8850	29
12	230	50	470	208	0.98	50	58	57	6910	44
13	230	50	355	138	0.74	44	53	54	0	60
14	230	50	355	81	0.46	45	51	51	7715	8
15	230	50	355	90	0.51	43	49	49	6670	16
16	230	50	355	98	0.55	43	50	50	5220	25

U = Supply voltage · f = Frequency · n = Speed · P_{ed} = Power input · I = Current draw · LpA_{in} = Sound pressure level inlet side · LwA_{in} = Sound power level inlet side · LwA_{out} = Sound power level outlet side
 qv = Air flow · p_{fs} = Pressure increase

