

ebm-papst Mulfingen GmbH & Co. KG

Bachmühle 2  
D-74673 Mulfingen  
Phone +49 (0) 7938 81-0  
Fax +49 (0) 7938 81-110  
info1@de.ebmpapst.com  
www.ebmpapst.com

## CONTENTS

<b>1. SAFETY REGULATIONS AND INFORMATION</b>	<b>1</b>
1.1 Hazard levels for warnings	1
1.2 Staff qualifications	1
1.3 Basic safety rules	1
1.4 Voltage	1
1.5 Safety and protective features	2
1.6 Mechanical movement	2
1.7 Emissions	2
1.8 Hot surface	2
1.9 Transport	2
1.10 Storage	2
<b>2. INTENDED USE</b>	<b>3</b>
<b>3. TECHNICAL DATA</b>	<b>4</b>
3.1 Product drawing	4
3.2 Nominal data	5
3.3 Technical description	5
3.4 Mounting data	5
3.5 Transport and storage conditions	5
<b>4. CONNECTION AND STARTUP</b>	<b>6</b>
4.1 Mechanical connection	6
4.2 Electrical connection	6
4.3 Connection in terminal box	7
4.4 Connection diagram	9
4.5 Opening additional cable glands	10
4.6 Checking connections	10
4.7 Switching on the device	10
4.8 Switching off the device	10
<b>5. MAINTENANCE, MALFUNCTIONS, POSSIBLE CAUSES AND REMEDIES</b>	<b>10</b>
5.1 Cleaning	11
5.2 Safety inspection	11
5.3 Disposal	11

## 1. SAFETY REGULATIONS AND INFORMATION

Read these operating instructions carefully before starting work on the device. Observe the following warnings to prevent malfunctions or danger to persons.

These operating instructions are to be regarded as part of the device. The device is only to be sold or passed on together with the operating instructions.

These operating instructions may be duplicated and distributed to inform about potential dangers and their prevention.

### 1.1 Hazard levels for warnings

These operating instructions use the following hazard levels to indicate potentially hazardous situations and important safety regulations:



#### DANGER

Indicates an imminently hazardous situation which will result in death or serious injury if the specified actions are not taken. Compliance with the instructions is imperative.

#### WARNING

Indicates a potentially hazardous situation which can result in death or serious injury if the specified actions are not taken. Exercise extreme caution while working.

#### CAUTION

Indicates a potentially hazardous situation which can result in minor or moderate injury or damage to property if the specified actions are not taken.

#### NOTE

A potentially harmful situation can occur and, if not avoided, can lead to property damage.

### 1.2 Staff qualifications

The device may only be transported, unpacked, installed, operated, maintained and otherwise used by suitably qualified, trained and authorized technical staff.

Only authorized specialists are permitted to install the device, to carry out a test run and to perform work on the electrical installation.

### 1.3 Basic safety rules

The safety hazards associated with the device must be assessed again following installation in the final product.

Note the following when working on the device:

⇒ Do not perform any modifications, additions or conversions on the device without the approval of ebm-papst.

### 1.4 Voltage

⇒ Check the device's electrical equipment at regular intervals; see Chapter 5.2 Safety inspection.

⇒ Replace loose connections and defective cables immediately.



#### DANGER

#### Electrically charged device

Risk of electric shock

→ When working on an electrically charged device, stand on a rubber mat.

#### WARNING

#### Live terminals and connections even with device switched off

Electric shock

- Wait five minutes after disconnecting the voltage at all poles before opening the device.

**CAUTION**

**In the event of a fault, the rotor and the impeller will be energized**

The rotor and the impeller have basic insulation.

- Do not touch the rotor and impeller once installed.

**CAUTION**

**The motor restarts automatically when operating voltage is applied, e.g. after a power failure.**

Risk of injury

- Keep out of the device's danger zone.
- When working on the device, switch off the line voltage and ensure that it cannot be switched back on.
- Wait until the device comes to a stop.
- Install the externally wired thermal overload protector in the control circuit so that following a malfunction the motor does not switch on again automatically after cooling off.

## 1.5 Safety and protective features



**DANGER**

**Protective device missing and protective device not functioning**

Without a protective device there is a risk of serious injury, for instance when reaching into the device during operation.

- Operate the device only with a fixed protective device and guard grille.
- The fixed protective device must be able to withstand the kinetic energy of a fan blade that becomes detached at maximum speed. There must not be any gaps which it is possible to reach into with the fingers, for example.
- The device is a built-in component. As the operator, you are responsible for ensuring that the device is secured adequately.
- Stop the device immediately if you notice a missing or ineffective protective device.

## 1.6 Mechanical movement



**DANGER**

**Rotating device**

Risk of injury to body parts coming into contact with the rotor or the impeller.

- Secure the device against accidental contact.
- Before working on the system/machine, wait until all parts have come to a standstill.

**WARNING**

**Rotating device**

Long hair and dangling items of clothing, jewelry and the like can become entangled and be pulled into the device. Injuries can result.

- Do not wear any loose-fitting or dangling clothing or jewelry while working on rotating parts.
- Protect long hair with a cap.

## 1.7 Emissions

**WARNING**

**Depending on the installation and operating conditions, the sound pressure level may exceed 70 dB(A).**

Risk of noise-induced hearing loss

- Take appropriate technical safety measures.
- Protect operating personnel with appropriate safety equipment such as hearing protection.
- Also observe the requirements of local agencies.

## 1.8 Hot surface



**CAUTION**

**High temperature on motor housing**

Risk of burns

- Ensure sufficient protection against accidental contact.

## 1.9 Transport

**NOTE**

**Transporting the device**

- Transport the device in its original packaging only.
- Secure the device so it cannot slip, e.g. by using a lashing strip.

## 1.10 Storage

- ⇒ Store the device, partially or fully assembled, in a dry and weatherproof manner in the original packaging in a clean environment.
- ⇒ Protect the device against environmental effects and dirt until final installation.
- ⇒ We recommend storing the device for no longer than one year in order to guarantee trouble-free operation and the longest possible service life.
- ⇒ Even devices explicitly intended for outdoor use are to be stored as described prior to commissioning.
- ⇒ Maintain the storage temperature, see Chapter 3.5 Transport and storage conditions.
- ⇒ Make sure that all cable glands are fitted with dummy plugs.

## 2. INTENDED USE

The device is exclusively designed as a built-in device for conveying air according to its technical data.

Any other usage above and beyond this does not conform with the intended purpose and constitutes misuse of the device.

Customer equipment must be capable of withstanding the mechanical and thermal stresses that can arise from this product. This applies for the entire service life of the equipment in which this product is installed.

### Intended use also includes

- Using the device solely outside of the EU.
- Using the device only in stationary systems.
- Performing all maintenance work.
- conveying air at an ambient air pressure between 750 mbar and 1050 mbar.
- Using the device within the permitted ambient temperature range; see Chapter 3.5 Transport and storage conditions and Chapter 3.2 Nominal data.
- Operating the device with all protective devices.
- Following the operating instructions.

### Improper use

In particular, operating the device in the following ways is prohibited and could be hazardous:

- Operating the device in an unbalanced state, e.g. due to dirt deposits or ice formation.
- Operation in medical equipment with a life-sustaining or life-support function.
- Operation with external vibrations.
- Conveying solids in the flow medium.
- Painting the device
- Connections (e.g. screws) coming loose during operation.
- Opening the terminal box during operation.
- Conveying air that contains abrasive particles.
- Conveying highly corrosive air, e.g. salt spray. Exception: devices designed for salt spray and correspondingly protected.
- Conveying air with high dust content, e.g. suctioning off sawdust.
- Operating the device close to flammable materials or components.
- Operating the device in an explosive atmosphere.
- Using the device as a safety component or to perform safety-related functions.
- Operation with completely or partially disassembled or manipulated protective devices.
- In addition, all applications not listed among the intended uses.

3. TECHNICAL DATA

3.1 Product drawing

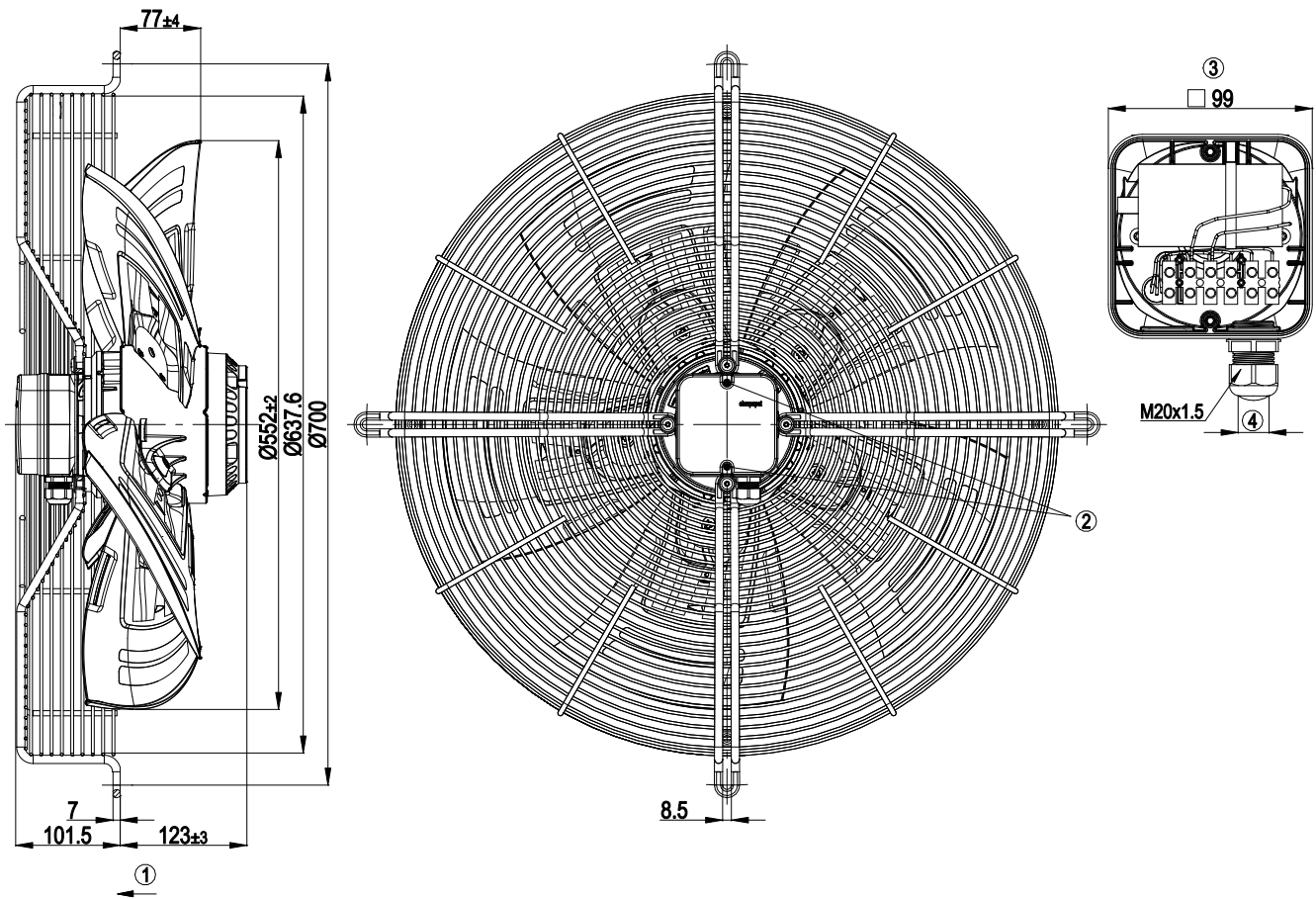

All dimensions in mm.

1	Direction of air flow "V"
2	Tightening torque 0.8±0.15 Nm
3	Shown without terminal box cover
4	Cable diameter min. 6 mm, max. 12 mm, tightening torque 2.0±0.3 Nm

Translation of the original operating instructions

3.2 Nominal data

Motor	M4E110-IA
Phase	1~
Nominal voltage / VAC	230
Frequency / Hz	50
Method of obtaining data	ml
Valid for approval/standard	-
Speed (rpm) / min <sup>-1</sup>	1275
Power consumption / W	1090
Current draw / A	4.76
Capacitor / μF	20
Capacitor voltage / VDB	450
Max. back pressure / Pa	160
Min. ambient temperature / °C	-40
Max. ambient temperature / °C	55
Max. safe operating speed (rpm) / min <sup>-1</sup>	1650

ml = Max. load · me = Max. efficiency · fa = Free air  
 cs = Customer specification · ce = Customer equipment

Subject to change

3.3 Technical description

Weight	20 kg
Fan size	560 mm
Rotor surface	Cast in aluminum
Terminal box material	ABS plastic
Blade material	Sheet aluminum insert, sprayed with PP plastic
Guard grille material	Steel, coated with black plastic (RAL 9005)
Number of blades	5
Blade pitch	-5°
Airflow direction	"V"
Direction of rotation	Counterclockwise, viewed toward rotor
Degree of protection	IP54
Insulation class	"F"
Moisture (F) / Environmental (H) protection class	F3-1
Installation position	Shaft horizontal or rotor on bottom; rotor on top on request
Condensation drainage holes	On rotor side
Mode	S1
Motor bearing	Ball bearing
Touch current according to IEC 60990 (measuring circuit Fig. 4, TN system)	<= 3.5 mA
Electrical hookup	Via terminal box, capacitor integrated and connected

Motor protection	Thermal overload protector (TOP) with basic insulation
with cable	Axial
Protection class	I (with customer connection of protective earth)
Motor capacitor according to EN 60252-1 in safety protection class	P0/S0
Conformity with standards	EN 61800-5-1
Approval	EAC; VDE



With regard to cyclic speed loads, note that the rotating parts of the device are designed for a maximum of one million load cycles. If you have special questions, consult ebm-papst for support.

3.4 Mounting data

⇒ Secure the screws against unintentional loosening (e.g. use self-locking screws).

Strength class of screws	8.8
--------------------------	-----

Any further mounting data required can be taken from the product drawing.

3.5 Transport and storage conditions

⇒ Use the device in accordance with its degree of protection.

Max. permitted ambient temp. for motor (transport/storage)	+ 80 °C
Min. permitted ambient temp. for motor (transport/storage)	- 40 °C

Translation of the original operating instructions



4. CONNECTION AND STARTUP

4.1 Mechanical connection



**CAUTION**

**Cutting and crushing hazard when removing fan from packaging**



→ Carefully remove the device from its packaging, by the guard grille. Strictly avoid shocks.

→ Wear safety shoes and cut-resistant safety gloves.

**CAUTION**

**Heavy load when unpacking device**

Risk of physical injury, such as back injuries.

→ Two people should work together to remove the device from its packaging.

- ⇒ Check the device for transport damage. Damaged devices are not to be installed.
- ⇒ Install the undamaged device in accordance with your application.
- ⇒ Do not perform any modifications, additions or conversions on the device. Replacing the terminal box is not permitted.



**NOTE**

**Motor capacitor**

→ The product is equipped with a motor capacitor with safety protection class P0/S0 according to EN 60252-1. Take this into consideration when fitting it to the end product on the basis of applicable regulations.



**CAUTION**

**Possible damage to the device**

If the device slips during installation, serious damage can result.

→ Ensure that the device is securely positioned at its place of installation until all fastening screws have been tightened.

4.2 Electrical connection



**DANGER**

**Voltage on the device**

Electric shock

→ Always connect a protective earth first.

→ Check the protective earth.



**DANGER**

**Faulty insulation**

Risk of fatal injury from electric shock

→ Use only cables that meet the specified installation regulations for voltage, current, insulation material, capacity, etc.

→ Route cables so that they cannot be touched by any rotating parts.



**DANGER**

**Electrical charge (>50 µC) between phase conductor and protective earth connection after switching off supply with multiple devices connected in parallel.**

Electric shock, risk of injury

→ Ensure sufficient protection against accidental contact. Before working on the electrical hookup, short the supply and PE connections.

**CAUTION**

**Voltage**

The fan is a built-in component and has no disconnecting switch.

→ Only connect the fan to circuits that can be switched off with an all-pole disconnection switch.

→ When working on the fan, secure the system/machine in which the fan is installed so as to prevent it from being switched back on.

**NOTE**

**Water ingress into wires or cables**

Water ingress at the customer end of the cable can damage the device.

→ Make sure the end of the cable is connected in a dry environment.



Only connect the device to circuits that can be switched off with an all-pole disconnection switch.

4.2.1 Requirements

- ⇒ Check whether the data on the nameplate match the connection data and the data for the operating capacitor.
- ⇒ Before connecting the device, make sure the power supply matches the device voltage.
- ⇒ Only use cables designed for the current level indicated on the nameplate.  
For determining the cross-section, note the sizing criteria according to EN 61800-5-1. The protective earth must have a cross-section equal to or greater than that of the phase conductor.  
We recommend the use of 105 °C cables. Ensure that the minimum cable cross-section is at least AWG 26 / 0.13 mm².

**Ground conductor contact resistance according to EN 61800-5-1**

Compliance with the impedance specifications according to EN 61800-5-1 for the protective earth connection circuit must be verified in the end application.

Depending on the circumstances of installation, it may be necessary to connect an additional protective earth conductor to the extra protective earth terminal on the device.

The protective earth terminal is on the housing and has a ground conductor symbol and a bore hole.

4.2.2 Residual current circuit breaker (RCCB)



Only pulse-current sensitive and/or universal residual current devices (type A or B) are permitted. As with variable frequency drives, residual current devices cannot provide personal safety while operating the device.

4.2.3 Voltage control



With speed control using transformers or electronic voltage regulators (e.g. phase control), excessive current may occur. In addition, depending on how the device is installed, noises can occur with phase control.



**4.2.4 Variable frequency drive**

Please use a variable frequency drive only after consultation with ebmpapst. When a variable frequency drive is used for speed adjustment, the maximum safe operating speed (see 3.2 Nominal data) may not be exceeded.



For operation with variable frequency drives, install sinusoidal filters that work on all poles (phase-phase and phase-ground) between the drive and the motor. During operation with variable frequency drives, an all-pole sine filter protects the motor against high-voltage transients that can destroy the coil insulation system, and against harmful bearing currents.

Heating of the motor due to use of a variable frequency drive must be checked in the application by the customer.

**4.3 Connection in terminal box**

**4.3.1 Preparing cables for connection**

Only strip the cable as far as necessary, ensuring that the cable gland is sealed and there is no strain on the connections. For tightening torques, see Chapter 3.1 Product drawing.



**NOTE**  
Tightness and strain relief are dependent on the cable used.

→ This must be checked by the user.

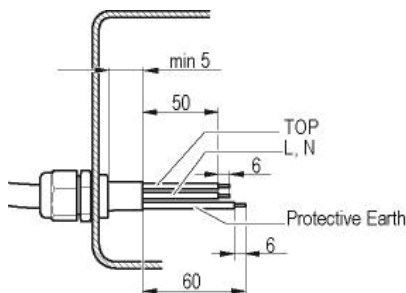

**4.3.2 Connecting wires to terminals**

- ⇒ Remove the cap from the cable gland.
  - Only remove caps where cables are fed in.
  - ⇒ Route the wire(s) (not included in scope of delivery) into the terminal box.
  - ⇒ First connect the "PE" (protective earth).
  - ⇒ Connect the wires to the corresponding terminals.
  - ⇒ Connect the thermal overload protector (TOP).
- Use a screwdriver to do so. When connecting, ensure that no wire ends fan out. The terminal strip is equipped with a penetration guard.
- ⇒ Insert the leads until they meet resistance.
  - ⇒ Seal the terminal box.

**4.3.3 Cable routing**

Water must be prevented from reaching the cable gland along the cable.

**Fans installed lying flat**

Make sure the cable is routed in a U-shaped loop.

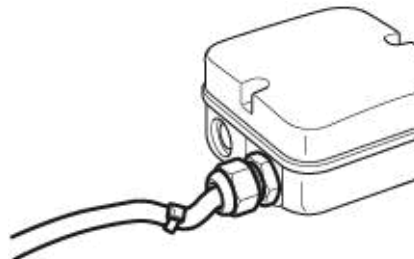

Fig. 2: Fan installed lying flat, cable routed in a U-shaped loop.

**Fans installed upright**

When routing the cable, make sure that the cable glands are located at the bottom. The cables must always be routed downward.

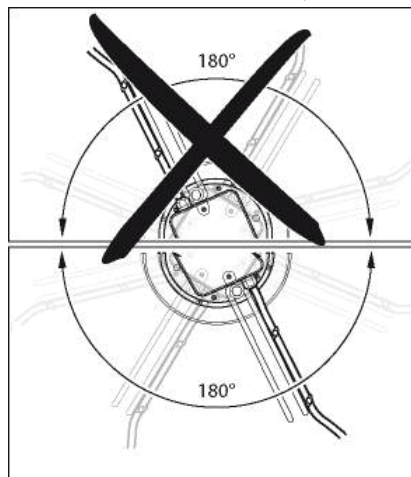

Fig. 3: Cable routing for fans installed upright.

**4.3.4 Motor protection**

**CAUTION**

**Voltage**

The device is a built-in component and has no disconnecting switch.

- Connect the device to a suitable tripping unit.
- Only connect the device to circuits that can be switched off with an all-pole disconnection switch.
- When working on the device, secure the system/ machine in which the device is installed so as to prevent it from being switched back on.

**NOTE**

**Lack of motor protection**

Without motor protection, the motor can overheat and suffer damage.

- Connect the thermal overload protector installed in the winding.

The motors are equipped with thermal overload protectors to protect the devices.

Check to make sure that the thermal overload protector is correctly connected before each operation.



S4E560-AQ01-01

# Operating instructions

Failure to connect the thermal overload protector correctly will invalidate your warranty claim.





## 4.4 Connection diagram

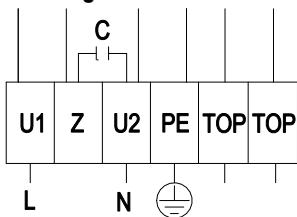

<b>L</b>	= U1 = blue
<b>Z</b>	brown
<b>N</b>	= U2 = black
<b>PE</b>	green/yellow
<b>TOP</b>	gray

**4.5 Opening additional cable glands**

A second cable gland opening can be made in the terminal box.

**WARNING**

**In the event of a fault, the cable gland is energized**

Electric shock

→ Do not use metal cable glands with plastic terminal boxes.

- ⇒ Screw the cable gland into the precut thread using a wrench. When doing so, take note of the tightening torques; see Chapter 3.1 Product drawing.
- ⇒ Remove the plastic tab that fell off inside the terminal box when it was penetrated.

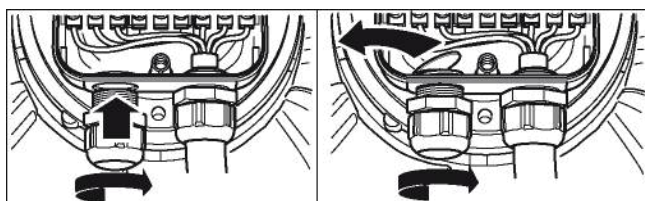

Fig. 4: Cable gland opening



**NOTE**

**Tightness and strain relief are dependent on the cable used.**

→ This must be checked by the user.

**4.6 Checking connections**

- ⇒ Ensure isolation from supply (all phases).
- ⇒ Make sure a restart is impossible
- ⇒ Check the cables for proper fit.
- ⇒ Screw the terminal box cover back on again. Terminal box tightening torque, see Chapter 3.1 Product drawing.
- ⇒ Make sure the terminal box is completely closed and sealed and that all screws and cable glands have been properly tightened.

**4.7 Switching on the device**

The device may only be switched on if it has been installed properly and in accordance with its intended use, including the required safety mechanisms and professional electrical hookup. This also applies for devices which have already been equipped with plugs and terminals or similar connectors by the customer.



**WARNING**

**Hot motor housing**

Risk of fire

→ Ensure that no combustible or flammable materials are located close to the fan.

- ⇒ Before switching on, check the device for visible external damage and make sure the protective devices are functional.
- ⇒ Check the fan's air flow paths for foreign matter and remove any foreign matter found.
- ⇒ Apply the nominal supply voltage.

**4.8 Switching off the device**

- ⇒ Disconnect the device from the power supply at the supply line's main switch.
- ⇒ When disconnecting, be sure to disconnect the ground connection last.

**5. MAINTENANCE, MALFUNCTIONS, POSSIBLE CAUSES AND REMEDIES**

Do not perform any repairs on your device. Send the device to ebmpapst for repair or replacement.

**WARNING**

**Live terminals and connections even with device switched off**

Electric shock

→ Wait five minutes after disconnecting the voltage at all poles before opening the device.

**CAUTION**

**Electric charge on capacitor after device is switched off**

Electric shock, risk of injury

→ Discharge the capacitors before working on the device.

**CAUTION**

**The motor restarts automatically when operating voltage is applied, e.g. after a power failure.**

Risk of injury

→ Keep out of the device's danger zone.

→ When working on the device, switch off the line voltage and ensure that it cannot be switched back on.

→ Wait until the device comes to a stop.

→ Install the externally wired thermal overload protector in the control circuit so that following a malfunction the motor does not switch on again automatically after cooling off.



If the device is out of use for some time, e.g. when in storage, we recommend switching it on for at least two hours to allow any condensation to evaporate and to move the bearings.

Malfunction/fault	Possible cause	Possible remedy
Impeller not running smoothly	Imbalance in rotating parts	Clean the device; replace it if imbalance persists after cleaning. Make sure no weight clips are removed during cleaning.
Motor not turning	Mechanical blockage	Switch off, isolate from supply and remove mechanical blockage.
	Line voltage faulty	Check line voltage, restore power supply.
	Faulty connection	Isolate from supply, correct connection; see connection diagram.



	Thermal overload protector activated	Allow motor to cool off, locate and rectify cause of error, release restart lockout if necessary
	Impermissible point of operation	Check point of operation
<b>Motor overtemperature</b>	Ambient temperature too high	Reduce ambient temperature if possible
	Deficient cooling	Improve cooling



In the event of further malfunctions, contact ebm-papst.

## 5.1 Cleaning

### NOTE

#### Damage to the device during cleaning

Malfunction possible

- Do not clean the device using a water jet or high-pressure cleaner.
- Do not use any acid, alkali or solvent-based cleaning agents.
- Do not use any pointed or sharp-edged objects for cleaning

## 5.2 Safety inspection

What to check	How to check	How often	What action?
Contact protection cover for intactness or damage	Visual inspection	At least every 6 months	Repair or replacement of device
Device for damage to blades and housing	Visual inspection	At least every 6 months	Replacement of device
Fastening the cables	Visual inspection	At least every 6 months	Fasten
Fastening the protective earth terminal	Visual inspection	At least every 6 months	Fasten
Insulation of cables for damage	Visual inspection	At least every 6 months	Replace cables
Tightness of cable gland	Visual inspection	At least every 6 months	Retighten, replace if damaged
Condensation drainage holes for clogging, where necessary	Visual inspection	At least every 6 months	Open holes
Welds for crack formation	Visual inspection	At least every 6 months	Replace device

## 5.3 Disposal

For ebm-papst, environmental protection and resource preservation are top priority corporate goals.

ebm-papst operates an environmental management system which is certified in accordance with ISO 14001 and rigorously implemented around the world on the basis of German standards.

Right from the development stage, ecological design, technical safety and health protection are fixed criteria.

The following section contains recommendations for ecological disposal of the product and its components.

### 5.3.1 Country-specific legal requirements



#### NOTE

#### Country-specific legal requirements

Always observe the applicable country-specific legal regulations with regard to the disposal of products or waste occurring in the various phases of the life cycle. The corresponding disposal standards are also to be heeded.

### 5.3.2 Disassembly

Disassembly of the product must be performed or supervised by qualified personnel with the appropriate technical knowledge.

The product is to be disassembled into suitable components for disposal employing standard procedures for motors.



#### WARNING

**Heavy parts of the product may drop off. Some of the product components are heavy. These components could drop off during disassembly.**

This can result in fatal or serious injury and material damage.

→ Secure components before unfastening to stop them falling.

### 5.3.3 Component disposal

The products are mostly made of steel, copper, aluminum and plastic. Metallic materials are generally considered to be fully recyclable.

Separate the components for recycling into the following categories:

- Steel and iron
- Aluminum
- Non-ferrous metal, e.g. motor windings
- Plastics, particularly with brominated flame retardants, in accordance with marking
- Insulating materials
- Cables and wires
- Electronic scrap, e.g. circuit boards

Only ferrite magnets and not rare earth magnets are used in external rotor motors from ebm-papst Mulfingen GmbH & Co. KG.

⇒ Ferrite magnets can be disposed of in the same way as normal iron and steel.

Electrical insulating materials on the product, in cables and wires are made of similar materials and are therefore to be treated in the same manner.

The materials concerned are as follows:

- Miscellaneous insulators used in the terminal box
- Power cables
- Cables for internal wiring
- Electrolytic capacitors



S4E560-AQ01-01

# Operating instructions

Dispose of electronic components employing the proper procedures for electronic scrap.



→ Please contact ebm-papst for any other questions on disposal.

